

KOMATSU

PC4000-11 Loading Shovel PC4000-11 Backhoe

ENGINE POWER

1400 kW / 1875 HP @ 1800 rpm

OPERATING WEIGHT

398 – 409 ton / 877,300 – 901,500 lb

SHOVEL CAPACITY

22 m³ 29 yd³ SAE 2:1 heaped

BACKHOE CAPACITY

22 m³ 29 yd³ SAE 1:1 heaped

PC
4000



HYDRAULIC EXCAVATOR

WALK-AROUND



Quality in Manufacturing

Commitment to „Quality and Reliability“

- Quality management ISO 9001
- Environmental management ISO 14001
- Occupational health and safety management system BS OHSAS 18001:2007
- High consistent quality through continuous investment in personnel, design and manufacturing systems and processes

Powerful Diesel Engine

Komatsu SDA16V160E-3 engine

- Rated 1400 kW at 1800 rpm
- SCR system (selective catalytic reduction)
- Electronic engine management
- Low engine emission levels EPA Tier 4
- Time saving Engine Oil Management System; Reserve Oil Supply and Eliminator Oil Filter System
- Higher fuel efficiency
- Extended service intervals

Reliability and Durability

Long life and low operating cost by design

- Robust structural design developed from field experience and finite element analysis

Undercarriage

- Large diameter rollers, idlers and sprockets
- Large surface area and extensive precision hardening of all engaging components reduce track wear
- Hardened track link pin bores

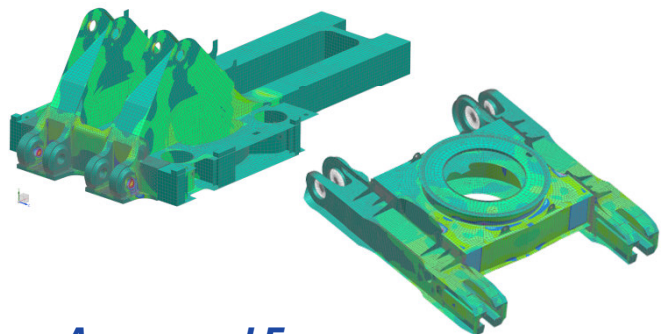

Access and Egress

- 45° primary access and egress stairways
- 45° access swing stairway
- 3 emergency egresses
 - cab and machinery house
 - (two pieces flip down solid anti slip steel ladder)
 - machinery house escape
- Illuminated accesses and egresses

MATCHES

150 to 240 U.S. ton TRUCKS

OPERATING WEIGHTShovel 398-403 ton
877,300-888,100 lbBackhoe 404-409 ton
890,700-901,500 lb**BUCKET CAPACITY**Shovel 22 m³ 29 yd³
Backhoe 22 m³ 29 yd³***Productivity***

Designed for more tons per hour

- Powerful digging forces
- Ease of bucket filling
- Proven attachment design
- All cylinders mounted in the shadow of the attachment for protection
- Various buckets and wear packages to suit all material densities and properties

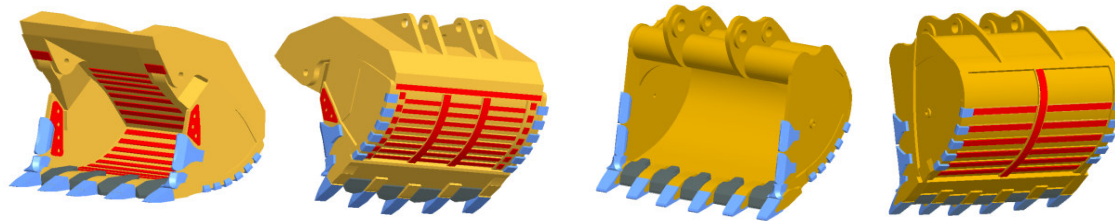
***Advanced Hydraulics***

Extended reliability and precise control

- Comprehensive monitored filtration
- Simple open circuit hydraulic system with high efficiency swing out oil coolers

Large Comfortable Cab

Comfortable for the whole day

- Komatsu low noise cab on multiple viscous mounts for reduced noise and vibration
- Large volume cab with full height front window
- Comprehensive climate control with pressurised filtered air ventilation and air conditioning
- High specification multi-adjustable air suspension seat plus trainer seat
- Well elevated operator position giving good all round view
- Large wash wiper covers windshield area for excellent visibility

Easy and Safe Maintenance

Simple, common-sense design provides easy access to all major components

- Generous access to all major service points from machinery house floor level
- Enclosed, walk-in machinery house with partition wall separating engine from pump area
- Automatic central lubrication
- KOMTRAX Plus electronic monitoring system providing real time information about the operating status of the machine
- Ground-level access to hydraulically powered swing down service arm with Wiggins connections
- Acknowledges EMESRT design philosophies

SPECIFICATIONS



DIESEL DRIVE

Tier 4 engine:
 Model Komatsu SDA16V160E-3
 Type 4-cycle, water-cooled, direct injection
 Aspiration Turbocharged and aftercooled
 Number of cylinders 16
 Rated power 1400 kW 1875 HP @ 1800 rpm (SAE 1995/J1349)
 Governor All-speed, electronic
 The integrated engine oil and filter system combining the oil stabilising systems, Reserve and Eliminator oil filter extends the oil change interval up to 1.000 hours. The high capacity Mesabi engine radiators are cooled by a hydraulically driven fan for superior cooling efficiency.
 The Engine meets EPA T4 final low emissions level by using Selective Catalytic Reduction and High Pressure Common Rail Injection System.



ELECTRIC SYSTEM (Diesel Version)

System 24 V
 Batteries (series/parallel) 2 x 2 x 12 V
 Alternator 260 A
 Standard working lights 14 LED lights
 Standard service lights throughout the platform incl. emergency egresses and stairways



UNDERCARRIAGE

Track adjustment Automatic hydraulic type
 Number of track shoes 49 each side
 Number of top rollers 3 each side
 Number of bottom rollers 7 each side



TRAVEL AND BRAKE SYSTEMS

Travel control 2 foot pedals
 Gradeability Up to 50 %
 Travel speed (maximum) 2,1 km/h 1.3 mph
 Service brake Hydraulic brake
 Parking brake Wet, multiple-disc



SWING SYSTEM

Hydraulic motors and drives 2
 Swing brake, service Hydraulic brake
 Swing brake, parking Wet, multiple-disc
 Swing ring teeth External
 Swing speed (maximum) 4.0 rpm



HYDRAULIC SYSTEM

The power train consists of one main drive. One gearbox drives four identical pumps which draw hydraulic oil from an unpressurised hydraulic tank. Open circuit hydraulics provide maximum cooling and filtering efficiency.

Rated flow (total output) 4.140 ltr/min / 1,096 gpm
 Relief valve setting 310 bar / 4,495 psi
 Swing flow rate 1.590 ltr/min / 420 gpm
 High pressure in line filters 200 microns one per pump located at the valve blocks
 Full flow return line filters 10 microns at head of hydraulic tank
 Case drain/by-pass return line filters 3 microns
 The four-circuit system features a load-limiting governor with oil delivery summation to the working circuits and incorporates pressure cut-off control. Hydropilot prioritises hydraulic flow giving smooth hydraulic response, simple hydraulic system layout, and a reduced number of components. The hydraulic system includes large swing-out vertical air-to-oil hydraulic coolers with temperature-regulated hydraulically driven fans.



AUTOMATIC CENTRALISED LUBRICATION

Two hydraulically powered Lincoln single line automatic lubrication systems are provided as standard, complete with time and volume variable controls. The central lube grease system is supplied from a refillable 200 litre (53 gal.) barrel. A second, identical system supplies open gear lubricant to the swing ring teeth through a lube pinion. Replenishment of the containers is through the Wiggins connections on the service arm.



SERVICE CAPACITIES

Hydraulic oil tank 3.900 ltr / 1,030 U.S. gal
 Hydraulic system 5.900 ltr / 1,559 U.S. gal
 Fuel 6.910 ltr / 1,826 U.S. gal
 Engine coolant 475 ltr / 125 U.S. gal
 Engine oil 290 ltr / 77 U.S. gal
 Reserve engine oil make up tank 460 ltr / 122 U.S. gal
 DEF (diesel exhaust fluid) tank 587 ltr / 155 U.S. gal

OPERATOR CAB

The large and comfortable cab is mounted on 18 viscous damping pads and sound insulated. The cab has automatic climate control and is pressurised. The operator's seat is air suspended, electrically heated and has a lap seat belt and offers multiple adjustments. The trainer seat is also equipped with a seat belt. Low-effort joystick controls are electro-hydraulic with foot controls for front shovel clam, crawler and swing brake. Full instrumentation, KOMTRAX Plus and an AM/FM radio with MP3 ready CD player with AUX in is fitted. The windshield wash wiper has two speeds and intermittent operation. Amenities include a refrigerator and storage cabinets. Powered and heated mirrors are adjusted from inside the cab. External metal sun blinds on the cab side window and internal roller blinds on all windows are standard. The left hand window is an emergency exit. All windows are tinted parsol green. The front window is a 19mm thick impact resistant window. A walkway is mounted in front of cabin.

Major cab engineering standards are:

- ISO 3449 Falling Objects Protection Structure (FOPS)
- ISO 6396 Noise in operator's cab is max. 75 dB(A)
- ISO 2631-1 Whole body vibration and shock below 0,5 m/s²
- ISO 5349-1 Hand-lever vibration lower than 2,5 m/s²
- ISO 10263-4 Heating and air conditioning second heater or air conditioner as option

KOMTRAX PLUS HEALTH MONITORING SYSTEM

KOMTRAX Plus is designed for Komatsu mining equipment to provide real time information about the operating status of the machine via a coloured display. The integrated digital storage provides a full event history and trend data, which can be downloaded by laptop. Optionally available are W-LAN or Orbcmm satellite transmission (check for availability in your territory).

OPERATING WEIGHTS (APPROXIMATE)

PC 4000 Backhoe:

Operating weight including 9.750 mm 32'0" boom, 4.500 mm 14'9" stick, 22 m³ (29 yd³) backhoe bucket, operator, lubricant, coolant, 1/3 fuel and standard equipment.

| Shoe Width | Operating Weight | Ground Pressure |
|----------------|---------------------|------------------------------------|
| 1200 mm 47" | 404 t 890,700 lb | 22,2 N/cm ² 32.2 psi |
| 1500 mm 59" | 409 t 901,500 lb | 17,9 N/cm ² 26 psi |

PC 4000 Front Shovel:

Operating weight including 7.150 mm 23'6" boom, 4.900 mm 16'1" stick, 22 m³ (29 yd³) shovel bucket, operator, lubricant, coolant, 1/3 fuel and standard equipment.

| Shoe Width | Operating Weight | Ground Pressure |
|----------------|---------------------|------------------------------------|
| 1200 mm 47" | 398 t 877,300 lb | 21,8 N/cm ² 31.6 psi |
| 1500 mm 59" | 403 t 888,100 lb | 17,7 N/cm ² 25.7 psi |

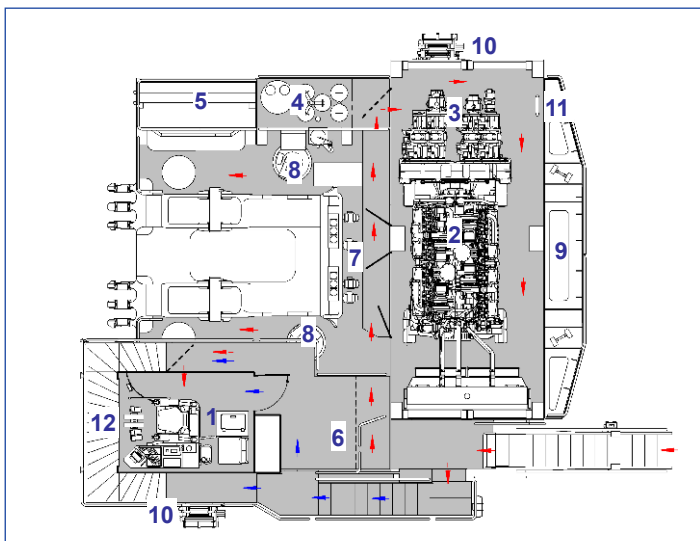

Diesel Drive

- 1 Cab
- 2 Diesel Engines
- 3 Hydraulic Pumps
- 4 Hydraulik Tank
- 5 Hydraulic Coolers
- 6 Fuel Tank
- 7 Valve Blocks
- 8 Swing Motors
- 9 Counterweight
- 10 Emergency swing ladder egress
- 11 Emergency access out of machinery house
- 12 See-through Cat Walk

Walkways ← Lower-Level
← Upper-Level

PRODUCTIVITY-FEATURES

BACKHOE ATTACHMENT

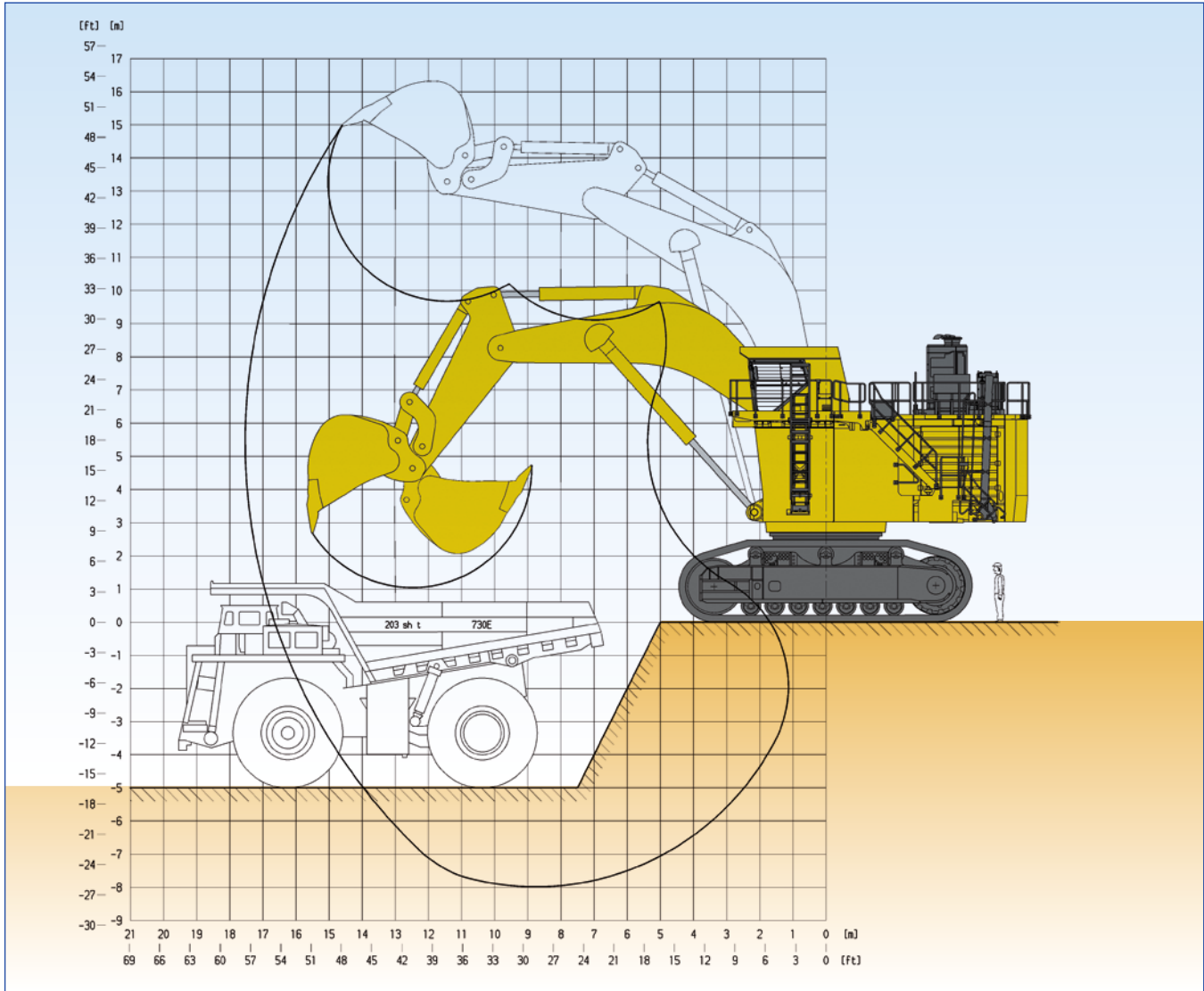

| | | |
|-----------------------|----------|------------|
| Boom length | 9.750 mm | 32'0" |
| Stick length | 4.500 mm | 14'9" |
| Break-out force (ISO) | 1.239 kN | 278,490 lb |
| Tear-out force (ISO) | 1.058 kN | 237,810 lb |

| | | |
|------------------------------------|-----------|--------|
| Max. digging height | 15.000 mm | 49'3" |
| Max. dumping height | 9.700 mm | 31'10" |
| Max. digging depth | 8.000 mm | 26'3" |
| Max. digging reach | 17.500 mm | 57'5" |
| Max. digging reach at ground level | 16.650 mm | 54'8" |

| Bucket Capacity (Heaped 1:1) SAE | | Width | | Teeth | Wear Package acc. abrasiveness | GET System | Max. Material Density (Loose) | |
|-------------------------------------|------|-------|-----------|-------|--------------------------------------|------------------|----------------------------------|---------|
| cum | cuyd | mm | foot/inch | qty | | | t/cum | lb/cuyd |
| 19,0 | 25.0 | 3.050 | 10'0" | 5 | heavy | Hensley XS 342 * | 2,1 | 3,400 |
| 22,0 | 29.0 | 3.790 | 12'5" | 6 | standard | Hensley XS 342 * | 1,8 | 3,000 |
| 23,0 | 30.0 | 3.790 | 12'5" | 6 | standard | Hensley XS 342 * | 1,7 | 2,900 |

Alternative buckets on request

*other systems on request



FRONT SHOVEL ATTACHMENT

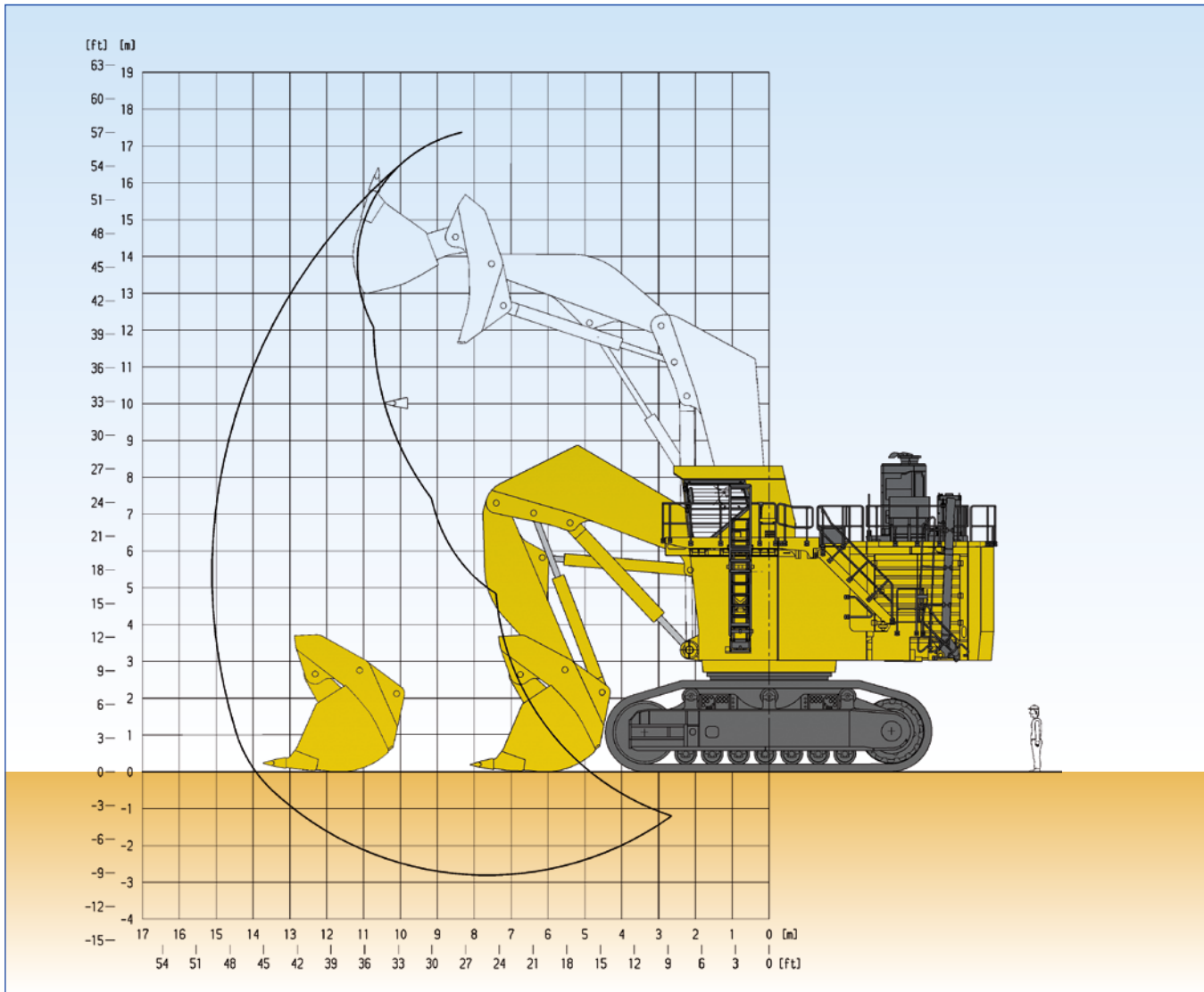

| | | |
|-----------------------|----------|------------|
| Boom length | 7.150 mm | 23'6" |
| Stick length | 4.900 mm | 16'1" |
| Break-out force (ISO) | 1.349 kN | 303,220 lb |
| Crowd force (ISO) | 1.330 kN | 298,950 lb |

| | | |
|-----------------------------|-----------|-------|
| Max. cutting height | 17.400 mm | 57'1" |
| Max. dumping height | 12.000 mm | 39'4" |
| Max. digging depth | 2.900 mm | 9'6" |
| Max. digging reach | 15.100 mm | 49'6" |
| Level crowd at ground level | 5.700 mm | 18'8" |
| Bucket opening width | 2.650 mm | 8'8" |

| Bucket Capacity (Heaped 1:2) SAE | | Width | | Teeth | Wear Package acc. abrasiveness | GET System | Max. Material Density (Loose) | |
|-------------------------------------|------|-------|-----------|-------|--------------------------------------|------------------|----------------------------------|---------|
| cum | cuyd | mm | foot/inch | qty | | | t/cum | lb/cuyd |
| 19,0 | 25.0 | 4.020 | 13'2" | 5 | heavy | Hensley XS 390 * | 2,1 | 3,400 |
| 22,0 | 29.0 | 4.020 | 13'2" | 5 | standard | Hensley XS 390 * | 1,8 | 3,000 |
| 23,0 | 30.0 | 4.020 | 13'2" | 5 | standard | Hensley XS 390 * | 1,7 | 2,900 |
| 24,0 | 31.5 | 4.020 | 13'2" | 5 | light | Hensley XS 390 * | 1,6 | 2,700 |

Alternative buckets on request

*other systems on request



STANDARD EQUIPMENT

HYDRAULIC MINING SHOVEL

FRONT SHOVEL ATTACHMENT

- 7,15 m 23'6" boom
- 4,9 m 16'1" stick
- Set of cylinders
- 22 m³ (29 yd³) (SAE 2:1) shovel bucket incl. standard wear package with hammerless GET system

OR

BACKHOE ATTACHMENT

- 9,75 m 32'0" boom
- 4,5 m 14'9" stick
- Set of cylinders
- 22 m³ (29 yd³) (SAE 1:1) bucket incl. standard wear package with hammerless GET system

CRAWLER UNDERCARRIAGE

- Heavy-duty shovel type undercarriage
- Centre carbody
- 2 heavy box-type track frames
- 7 bottom rollers and 3 top rollers each side
- 1200 mm 47" cast steel track shoes
- Hydraulic track adjustment and parking brake

SUPERSTRUCTURE

- Main frame mounted over an externally toothed swing circle carries the drive module
- Komatsu SDA16V160E-3 Tier 4 diesel engine
- Oil and fuel reservoirs
- Hydraulic components
- Counterweight

LIGHTING

- 14 LED high performance working lights
- Service lights throughout the platform incl. emergency egresses

OPERATOR CAB

- Enclosed steel cab mounted on viscous pads
- FOPS according ISO 3449
- Air-conditioning unit Süttrak
- Full suspension operator seat with belt
- Controls ergonomic
- KOMTRAX Plus (Monitoring System)
- Joysticks are electro-hydraulic
- 1 large parallel windshield wash wiper
- AM-FM radio with MP3 ready CD player & aux port
- Internal and external sun blinds
- All windows tinted parsol green
- Impact resistant front window (19mm)
- Walkway in front of cab

LUBRICATION AND SERVICE

- LINCOLN central lubrication for basic machine and attachment and bucket
- LINCOLN automatic pinion lubrication system for swing circle teeth
- WIGGINS service arm carrying fluid receiving connectors for filling of fuel, engine oil and coolant, hydraulic oil, grease, diesel exhaust fluid and the evacuation of coolant, hydraulic and engine oils

ACCESSORIES INCLUDED

- Acoustic travel alarm
- Hydraulically actuated ground access staircase
- 45° primary access and egress stairway
- 45° access swing stairway (hydraulically operated)
- 3 emergency egresses
 - cab and machinery house roof
 - machinery house escape
- Electric air horn
- Engine turbo and exhaust pipe covers
- Engine oil management package (Reserve & Eliminator systems)
- Service transfer oil pump
- Guard rails and steps on boom
- Tie off points on boom
- Engine emergency stop at ground level



OPTIONAL EQUIPMENT

ATTACHMENT/BUCKET

- Boom cylinder sliding guard
- Arm cylinder sliding guard
- Bucket cylinder sliding guard (BH)

UNDERCARRIAGE

- 1.500 mm 59" track shoes

POWER

- Electro drive various voltages
- Cable drum without cable
- Fire suppression system, Ansul (Agent LVS+Powder), diesel drive

COLD WEATHER

- Cold weather package down to -40° C (diesel and electro drive)
- Arctic weather package down to -50° C (diesel and electro drive)
- Hotstart temperature treatment for ambient temperature down to -50° C (diesel and electro drive), external power source not included

SPECIFIC HYDRAULIC OIL

- Biodegradable hydraulic oil

MISCELLANEOUS

- Camera system acc. ISO5006
- ProVision ready
- Additional LED working lights
- Rotafare warning lights
- Additional cab A/C
- Additional independent cab heater
- Special painting



DIMENSIONS

BASIC MACHINE WITH COUNTERWEIGHT

| | | | | | |
|----------------|---------|-------|----------------|--------|--------|
| A | 1200 mm | 3'11" | J | 3085mm | 10'2" |
| B | 1500 mm | 4'11" | K | 8670mm | 28'5" |
| C _A | 6750 mm | 22'2" | L | 7600mm | 24'11" |
| C _B | 7050 mm | 23'2" | M | 8310mm | 27'3" |
| D | 2480 mm | 8'2" | N _A | 4032mm | 13'3" |
| E | 930 mm | 3'11" | N _B | 4882mm | 15'11" |
| F | 3380 mm | 11'1" | O | 3505mm | 11'6" |
| G | 6700 mm | 22'0" | P | 8700mm | 20'0" |
| H | 8842 mm | 29'0" | Q | 6095mm | 25'2" |
| I | 3020 mm | 9'11" | Q _R | 6500mm | 21'4" |

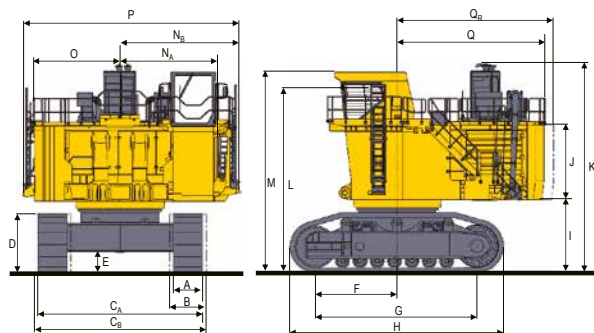

KOMATSU

Komatsu Germany GmbH

Büscherhofstrasse 10, 40599 Duesseldorf, Germany

Phone: +49 (0) 211 71 09-0, Fax: +49 (0) 211 71 58-22

info@komatsu-mining.de, www.komatsu-mining.de



QES0048 00